

DUAL WALL TO RCP MANHOLE ADAPTER FITTING WATER TIGHT CONNECTION

PART #	PIPE SIZE	A	B	OD
1222ANB	12 in (300 mm)	12.0 in (305 mm)	48.0 in (1219 mm)	14.8 in (375 mm)
1522ANB	15 in (375 mm)	14.5 in (368 mm)	46.6 in (1184 mm)	18.0 in (457 mm)
1822ANB	18 in (450 mm)	18.0 in (457 mm)	45.6 in (1157 mm)	21.8 in (552 mm)
2422ANB	24 in (600 mm)	24.0 in (610 mm)	47.3 in (1200 mm)	28.6 in (726 mm)
3022ANB	30 in (750 mm)	24.0 in (610 mm)	45.3 in (1151 mm)	35.9 in (913 mm)
3622ANB	36 in (900 mm)	24.0 in (610 mm)	46.3 in (1175 mm)	41.9 in (1063 mm)
4222ANB	42 in (1050 mm)	24.0 in (610 mm)	46.7 in (1186 mm)	48.5 in (1232 mm)
4822ANB	48 in (1200 mm)	24.0 in (610 mm)	47.3 in (1200 mm)	54.7 in (1388 mm)
6022ANB	60 in (1500 mm)	30.0 in (762 mm)	54.0 in (1372 mm)	67.5 in (1713 mm)

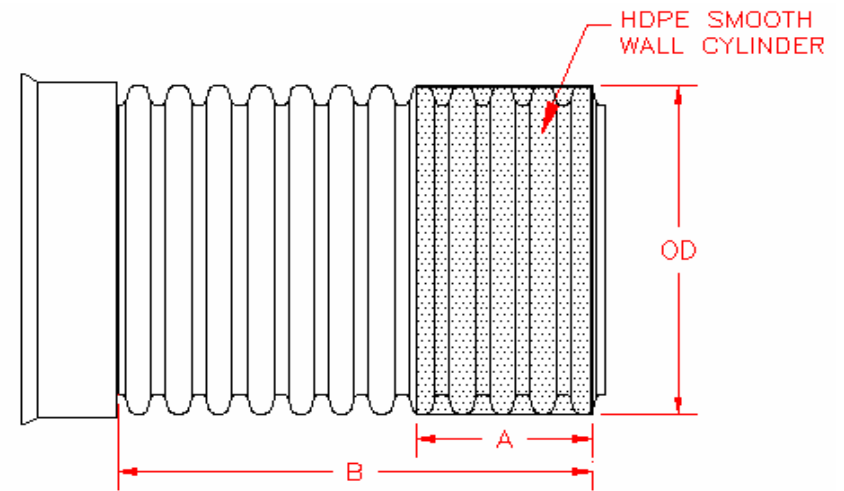

NOTE:
REQUIRES SERIES 65 GASKET (INCLUDED)
IN FIELD TO MAKE WT CONNECTION

NOTE: ALL DIMENSIONS ARE NOMINAL



DRAWING #:	6050	
DRAWN BY:	JCB	04.23.07
APPROVED BY:	JCB	06.28.07
REVISIONS:	NJP	06.20.07

DUAL WALL TO RCP MANHOLE ADAPTER FITTING WATER TIGHT CONNECTION

PART #	PIPE SIZE	A	B	OD
1222AN	12 in (300 mm)	12.0 in (305 mm)	48.0 in (1219 mm)	14.8 in (375 mm)
1522AN	15 in (375 mm)	14.5 in (368 mm)	46.6 in (1184 mm)	18.0 in (457 mm)
1822AN	18 in (450 mm)	18.0 in (457 mm)	45.6 in (1157 mm)	21.8 in (552 mm)
2422AN	24 in (600 mm)	24.0 in (610 mm)	47.3 in (1200 mm)	28.6 in (726 mm)
3022AN	30 in (750 mm)	24.0 in (610 mm)	45.3 in (1151 mm)	35.9 in (913 mm)
3622AN	36 in (900 mm)	24.0 in (610 mm)	46.3 in (1175 mm)	41.9 in (1063 mm)
4222AN	42 in (1050 mm)	24.0 in (610 mm)	46.7 in (1186 mm)	48.5 in (1232 mm)
4822AN	48 in (1200 mm)	24.0 in (610 mm)	47.3 in (1200 mm)	54.7 in (1388 mm)
6022AN	60 in (1500 mm)	30.0 in (762 mm)	54.0 in (1372 mm)	67.5 in (1713 mm)

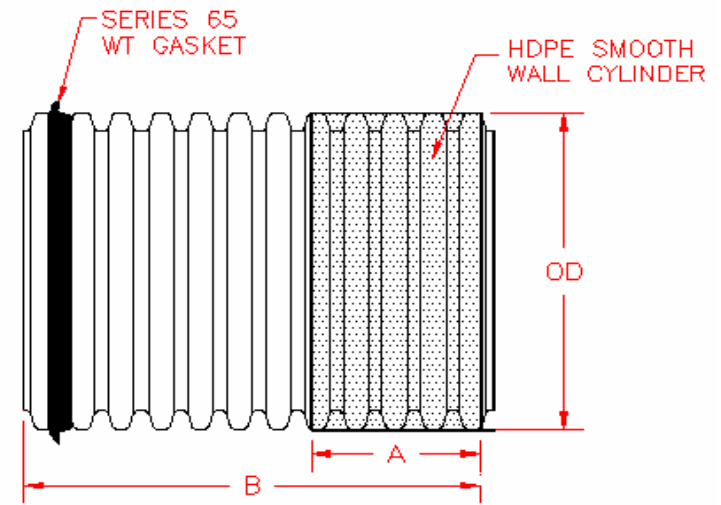

NOTE:

REQUIRES SERIES 65 GASKET (INCLUDED)
IN FIELD TO MAKE WT CONNECTION

NOTE: ALL DIMENSIONS ARE NOMINAL



DRAWING #:	6050A	
DRAWN BY:	JCB	04.23.07
APPROVED BY:	JCB	06.28.07
REVISIONS:	NJP	06.20.07

DUAL WALL ADAPTER FITTING

PART #	PIPE SIZE	A	B	OD
1221AN	12 in (300 mm)	6.0 in (152 mm)	11.5 in (293 mm)	12.1 in (306 mm)
1521AN	15 in (375 mm)	6.0 in (152 mm)	13.0 in (329 mm)	15.0 in (381 mm)
1821AN	18 in (450 mm)	6.0 in (152 mm)	13.4 in (340 mm)	18.0 in (457 mm)
2421AN	24 in (600 mm)	8.0 in (203 mm)	15.8 in (400 mm)	24.0 in (610 mm)
3021AN	30 in (750 mm)	10.0 in (254 mm)	20.6 in (523 mm)	30.0 in (762 mm)
3621AN	36 in (900 mm)	10.0 in (254 mm)	25.7 in (653 mm)	36.0 in (914 mm)
4221AN	42 in (1050 mm)	10.0 in (254 mm)	26.0 in (659 mm)	41.3 in (1048 mm)
4821AN	48 in (1200 mm)	10.0 in (254 mm)	26.3 in (667 mm)	47.6 in (1209 mm)
6021AN	60 in (1500 mm)	10.0 in (254 mm)	30.0 in (762 mm)	59.5 in (1511 mm)

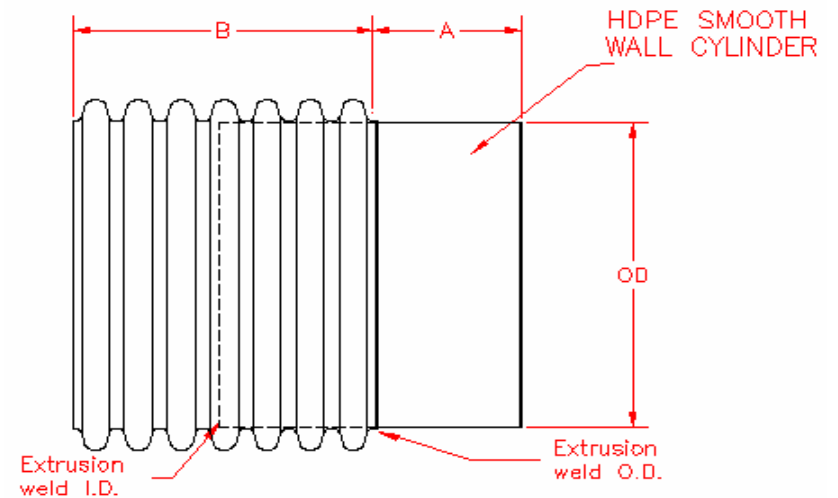

NOTE: ALL DIMENSIONS ARE NOMINAL



DRAWING #:	6055	
DRAWN BY:	JCB	03.20.07
APPROVED BY:	JCB	06.28.07
REVISIONS:	NJP	06.20.07

8" - 60" FIELD REPAIR COUPLER

PART #	PIPE SIZE	L	W
0867RC	8 in (200 mm)	35.0 in (889 mm)	4.0 in (102 mm)
1067RC	10 in (250 mm)	42.0 in (1067 mm)	6.0 in (152 mm)
1267RC	12 in (300 mm)	52.0 in (1321 mm)	7.0 in (178 mm)
1567RC	15 in (375 mm)	62.0 in (1575 mm)	10.0 in (254 mm)
1867RC	18 in (450 mm)	75.0 in (1905 mm)	10.0 in (254 mm)
2467RC	24 in (600 mm)	94.0 in (2388 mm)	12.0 in (305 mm)
3067RC	30 in (750 mm)	125.0 in (3175 mm)	15.0 in (381 mm)
3667RC	36 in (900 mm)	141.0 in (3581 mm)	18.0 in (457 mm)
4267RC	42 in (1050 mm)	161.0 in (4089 mm)	20.0 in (508 mm)
4867RC	48 in (1200 mm)	183.0 in (4648 mm)	20.0 in (508 mm)
6067RC	60 in (1500 mm)	222.0 in (5639 mm)	28.0 in (711 mm)

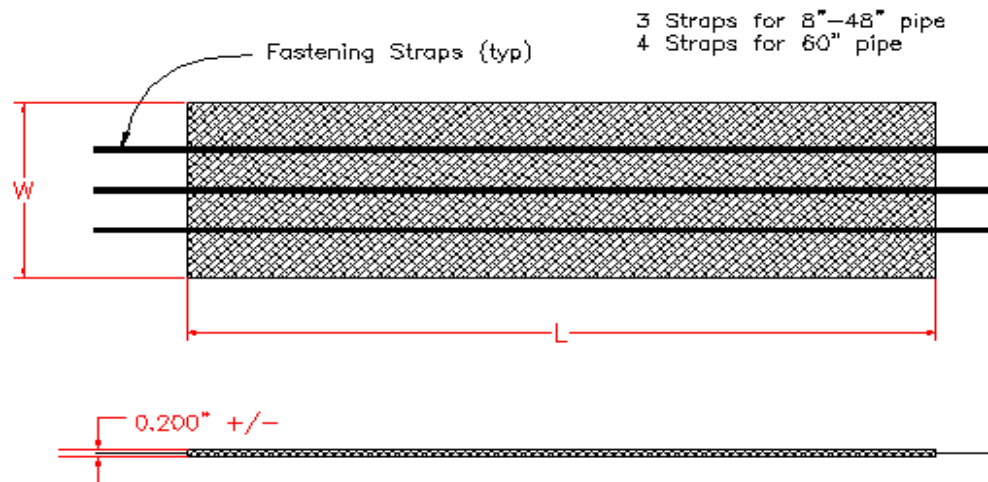

NOTE: ALL DIMENSIONS ARE NOMINAL

	DRAWING #:	6060	
	DRAWN BY:	JCB	03.20.07
	APPROVED BY:	JCB	06.28.07
	REVISIONS:	TJR	09.26.08

12" - 60" DOUBLE WIDE FIELD REPAIR COUPLER

PART #	PIPE SIZE	L	W	A
1267RCD	12 in (300 mm)	52.0 in (1321 mm)	12.0 in (305 mm)	2.0 in (51 mm)
1567RCD	15 in (375 mm)	62.0 in (1575 mm)	14.0 in (356 mm)	2.6 in (66 mm)
1867RCD	18 in (450 mm)	75.0 in (1905 mm)	16.0 in (406 mm)	2.8 in (70 mm)
2467RCD	24 in (600 mm)	94.0 in (2388 mm)	20.0 in (508 mm)	3.3 in (83 mm)
3067RCD	30 in (600 mm)	125.0 in (3175 mm)	24.0 in (610 mm)	4.5 in (114 mm)
3667RCD	36 in (600 mm)	141.0 in (3581 mm)	30.0 in (762 mm)	5.0 in (127 mm)
4267RCD	42 in (600 mm)	161.0 in (4089 mm)	30.0 in (762 mm)	5.5 in (140 mm)
4867RCD	48 in (600 mm)	183.0 in (4648 mm)	32.0 in (813 mm)	5.5 in (140 mm)
6067RCD	60 in (600 mm)	222.0 in (5639 mm)	46.0 in (1168 mm)	6.8 in (171 mm)

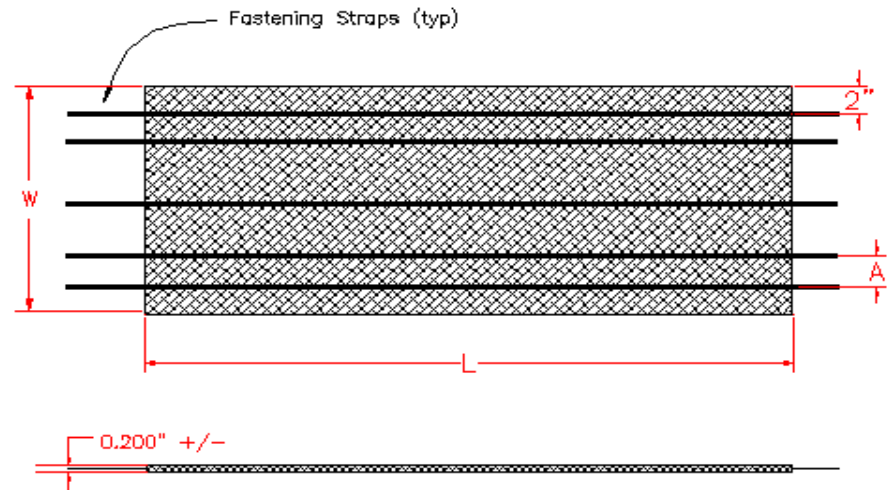

NOTE: ALL DIMENSIONS ARE NOMINAL

	DRAWING #:	6065
	DRAWN BY:	JCB 01.17.07
	APPROVED BY:	JCB 06.28.07
	REVISIONS:	TJR 09.26.08

FLARED END SECTIONS

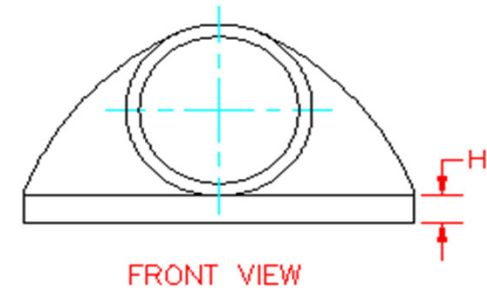
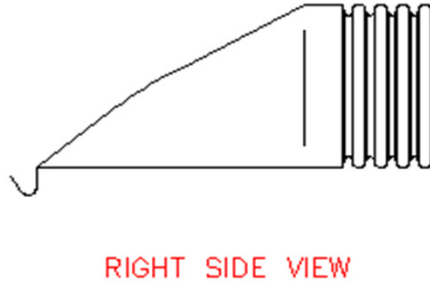
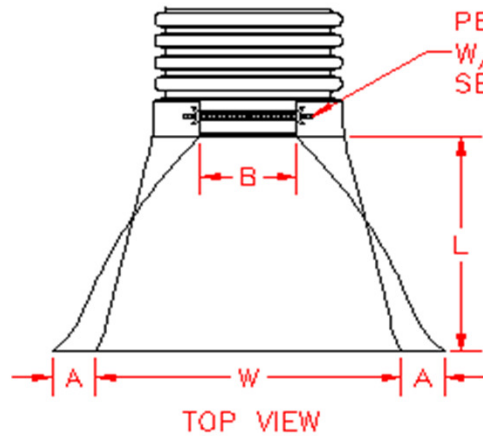

PART #	PIPE SIZE	A	B(MAX)	H	L	W
1015NP	10 in (250 mm)	3.8 in (95 mm)	10.0 in (254 mm)	6.5 in (165 mm)	28.0 in (711 mm)	34.5 in (876 mm)
1215NP	12 & 15 (300 & 375mm)	6.5 in (165 mm)	10.0 in (254 mm)	6.5 in (165 mm)	25.0 in (635 mm)	29.0 in (737 mm)
1810NP	18 in (450 mm)	7.5 in (191 mm)	15.0 in (381 mm)	6.5 in (165 mm)	32.0 in (813 mm)	35.0 in (889 mm)
2410NP	24 in (600 mm)	7.5 in (191 mm)	18.0 in (457 mm)	6.5 in (165 mm)	36.0 in (914 mm)	45.0 in (1143 mm)
3015NP	30 in (750 mm)	7.5 in (191 mm)	12.0 in (305 mm)	8.6 in (218 mm)	58.0 in (1473 mm)	63.0 in (1600 mm)
3615NP	36 in (900 mm)	7.5 in (191 mm)	25.0 in (635 mm)	8.6 in (218 mm)	58.0 in (1473 mm)	63.0 in (1600 mm)

NOTE: ALL DIMENSIONS ARE NOMINAL



DRAWING #:	6070	
DRAWN BY:	JCB	01.17.07
APPROVED BY:	JCB	06.28.07
REVISIONS:	TJR	6/7/2016

DUAL WALL JOINT PUSHER

PART #	PIPE SIZE
1208AN	12 in (300 mm)
1508AN	15 in (375 mm)
1808AN	18 in (450 mm)
2408AN	24 in (600 mm)
3008AN	30 in (750 mm)
3608AN	36 in (900 mm)
4208AN	42 in (1050 mm)
4808AN	48 in (1200 mm)
6006AN	60 in (1500 mm)

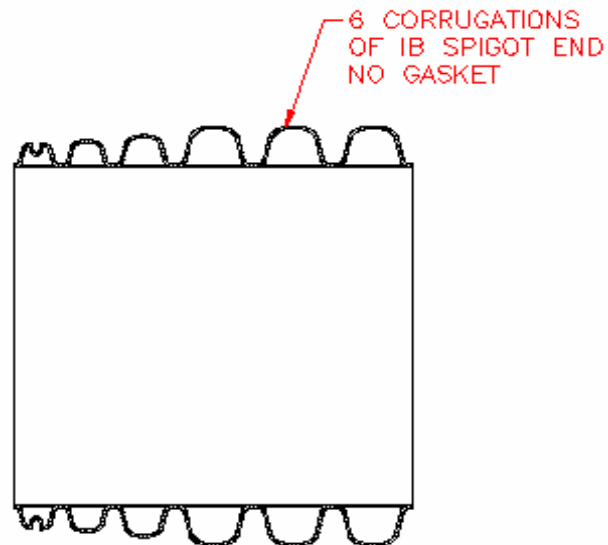

NOTE: ALL DIMENSIONS ARE NOMINAL



DRAWING #:	6085	
DRAWN BY:	JCB	03.20.07
APPROVED BY:	JCB	06.28.07
REVISIONS:	NJP	06.20.07

CATCH BASIN ELBOW

1/8" THICK ROLLED TAPER

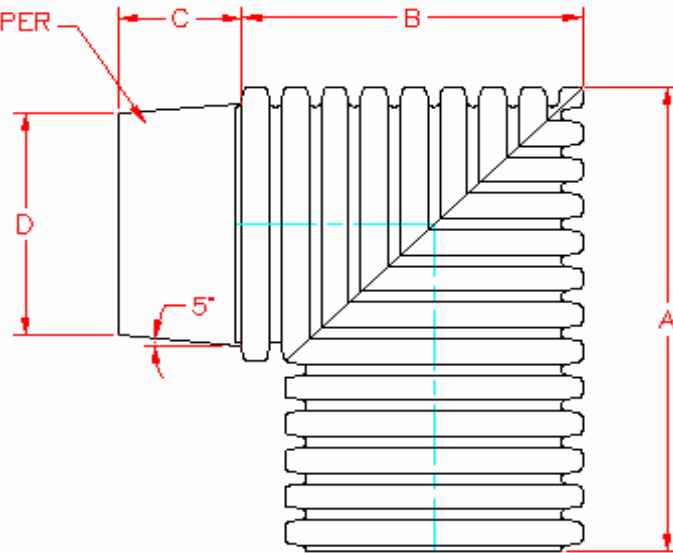

PART #	PIPE SIZE	A	B	C	D
0899ANCB	8 in (200 mm)	15.4 in (391 mm)	10.6 in (269 mm)	5.5 in (140 mm)	7.5 in (191 mm)
1099ANCB	10 in (250 mm)	18.9 in (480 mm)	11.3 in (287 mm)	5.5 in (140 mm)	9.5 in (241 mm)
1299ANCB	12 in (300 mm)	25.0 in (635 mm)	17.3 in (439 mm)	5.5 in (140 mm)	11.8 in (298 mm)

NOTE: ALL DIMENSIONS ARE NOMINAL



DRAWING #:	6090	
DRAWN BY:	JCB	03.20.07
APPROVED BY:	JCB	06.28.07
REVISIONS:	NJP	06.20.07

REDUCING TAP TEE (ST/WT CONNECTION)

PART #	PIPE SIZE	A	B	OD
0660AN65BS	6 x 4 in (150 x 100 mm)	8.5 in (216 mm)	9.5 in (241 mm)	4.3 in (108 mm)
0860AN65BS	8 x 4 in (200 x 100 mm)	11.5 in (293 mm)	11.0 in (279 mm)	4.3 in (108 mm)
0861AN65BS	8 x 6 in (200 x 150 mm)	11.5 in (293 mm)	10.6 in (270 mm)	6.3 in (159 mm)
1060AN65BS	10 x 4 in (250 x 100 mm)	15.1 in (384 mm)	12.0 in (305 mm)	4.3 in (108 mm)
1061AN65BS	10 x 6 in (250 x 150 mm)	15.1 in (384 mm)	12.0 in (305 mm)	6.3 in (159 mm)
1062AN65BS	10 x 8 in (250 x 200 mm)	15.1 in (384 mm)	12.0 in (305 mm)	8.6 in (218 mm)
1260AN65BS	12 x 4 in (300 x 100 mm)	19.5 in (496 mm)	13.1 in (333 mm)	4.3 in (108 mm)
1261AN65BS	12 x 6 in (300 x 150 mm)	19.5 in (496 mm)	13.1 in (333 mm)	6.3 in (159 mm)
1262AN65BS	12 x 8 in (300 x 200 mm)	19.5 in (496 mm)	13.1 in (333 mm)	8.6 in (218 mm)
1560AN65BS	15 x 4 in (375 x 100 mm)	23.6 in (600 mm)	14.8 in (375 mm)	4.3 in (108 mm)
1561AN65BS	15 x 6 in (375 x 150 mm)	23.6 in (600 mm)	14.8 in (375 mm)	6.3 in (159 mm)
1562AN65BS	15 x 8 in (375 x 200 mm)	23.6 in (600 mm)	14.8 in (375 mm)	8.6 in (218 mm)

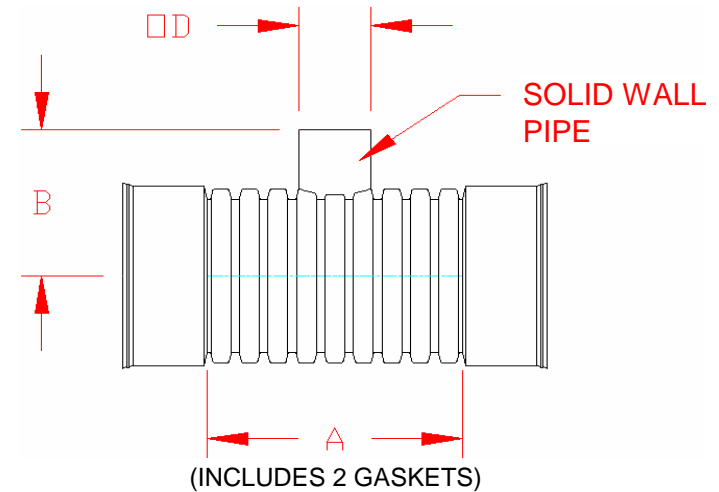

NOTE: ALL FITTINGS DIMENSIONS ARE FOR REFERENCE ONLY



DRAWING #:	6100	
DRAWN BY:	JCB	05.07.07
APPROVED BY:	JCB	06.28.07
REVISIONS:	NJP	06.20.07

REDUCING TAP TEE (ST/WT CONNECTION)

PART #	PIPE SIZE	A	B	OD
1860AN65BS	18 x 4 in (450 x 100 mm)	23.5 in (597 mm)	16.8 in (425 mm)	4.3 in (108 mm)
1861AN65BS	18 x 6 in (450 x 150 mm)	23.5 in (597 mm)	16.8 in (425 mm)	6.3 in (159 mm)
1862AN65BS	18 x 8 in (450 x 200 mm)	23.5 in (597 mm)	16.8 in (425 mm)	8.6 in (218 mm)
2460AN65BS	24 x 4 in (600 x 100 mm)	25.0 in (636 mm)	20.1 in (511 mm)	4.3 in (108 mm)
2461AN65BS	24 x 6 in (600 x 150 mm)	25.0 in (636 mm)	20.1 in (511 mm)	6.3 in (159 mm)
2462AN65BS	24 x 8 in (600 x 200 mm)	25.0 in (636 mm)	20.1 in (511 mm)	8.6 in (218 mm)
3060AN65BS	30 x 4 in (750 x 100 mm)	28.6 in (725 mm)	23.8 in (603 mm)	4.3 in (108 mm)
3061AN65BS	30 x 6 in (750 x 150 mm)	28.6 in (725 mm)	23.8 in (603 mm)	6.3 in (159 mm)
3062AN65BS	30 x 8 in (750 x 200 mm)	28.6 in (725 mm)	23.8 in (603 mm)	8.6 in (218 mm)
3660AN65BS	36 x 4 in (900 x 100 mm)	36.7 in (933 mm)	26.6 in (676 mm)	4.3 in (108 mm)
3661AN65BS	36 x 6 in (900 x 150 mm)	36.7 in (933 mm)	26.6 in (676 mm)	6.3 in (159 mm)
3662AN65BS	36 x 8 in (900 x 200 mm)	36.7 in (933 mm)	26.6 in (676 mm)	8.6 in (218 mm)

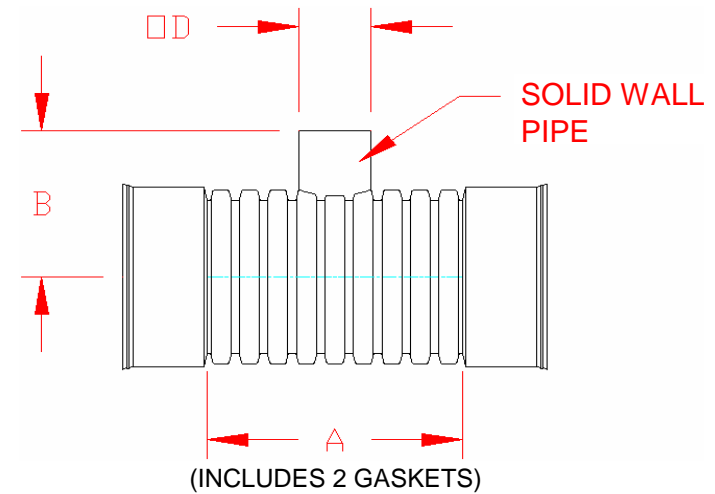

NOTE: ALL FITTINGS DIMENSIONS ARE FOR REFERENCE ONLY



DRAWING #:	6100A	
DRAWN BY:	JCB	05.07.07
APPROVED BY:	JCB	06.28.07
REVISIONS:	NJP	06.20.07

REDUCING TAP WYE (ST/WT CONNECTION)

PART #	PIPE SIZE	A	B	C	OD
0680AN65BS	6 x 4 in (150 x 100 mm)	11.8 in (300 mm)	16.0 in (405 mm)	9.2 in (234 mm)	4.3 in (109 mm)
0880AN65BS	8 x 4 in (200 x 100 mm)	15.4 in (391 mm)	17.3 in (439 mm)	12.1 in (307 mm)	4.3 in (109 mm)
0881AN65BS	8 x 6 in (200 x 150 mm)	15.4 in (391 mm)	19.7 in (499 mm)	12.1 in (307 mm)	6.3 in (160 mm)
1080AN65BS	10 x 4 in (250 x 100 mm)	19.0 in (483 mm)	18.7 in (475 mm)	14.5 in (368 mm)	4.3 in (109 mm)
1081AN65BS	10 x 6 in (250 x 150 mm)	19.0 in (483 mm)	21.1 in (535 mm)	14.5 in (368 mm)	6.3 in (160 mm)
1082AN65BS	10 x 8 in (250 x 200 mm)	19.0 in (483 mm)	23.4 in (594 mm)	14.5 in (368 mm)	8.6 in (218 mm)
1280AN65BS	12 x 4 in (300 x 100 mm)	33.7 in (857 mm)	18.4 in (467 mm)	25.6 in (650 mm)	4.3 in (109 mm)
1281AN65BS	12 x 6 in (300 x 150 mm)	33.7 in (856 mm)	19.4 in (493 mm)	25.6 in (650 mm)	6.3 in (160 mm)
1282AN65BS	12 x 8 in (300 x 200 mm)	33.7 in (856 mm)	21.1 in (536 mm)	25.6 in (650 mm)	8.6 in (218 mm)
1580AN65BS	15 x 4 in (375 x 100 mm)	34.2 in (869 mm)	18.4 in (467 mm)	25.6 in (650 mm)	4.3 in (109 mm)
1581AN65BS	15 x 6 in (375 x 150 mm)	34.2 in (869 mm)	19.4 in (493 mm)	25.6 in (650 mm)	6.3 in (160 mm)
1582AN65BS	15 x 8 in (375 x 200 mm)	34.2 in (869 mm)	21.1 in (536 mm)	25.6 in (650 mm)	8.6 in (218 mm)

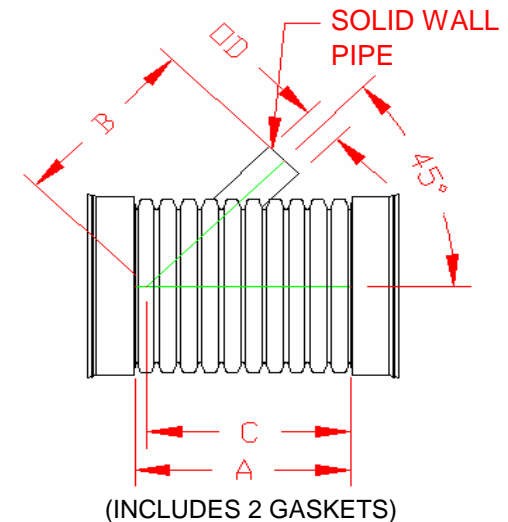

NOTE: ALL FITTINGS DIMENSIONS ARE FOR REFERENCE ONLY



DRAWING #:	6105	
DRAWN BY:	JCB	05.07.07
APPROVED BY:	JCB	06.28.07
REVISIONS:	NJP	06.20.07

REDUCING TAP WYE (ST/WT CONNECTION)

PART #	PIPE SIZE	A	B	C	OD
1880AN65BS	18 x 4 in (450 x 100 mm)	33.9 in (861 mm)	20.9 in (531 mm)	28.0 in (711 mm)	4.3 in (108 mm)
1881AN65BS	18 x 6 in (450 x 150 mm)	33.9 in (861 mm)	21.9 in (556 mm)	28.0 in (711 mm)	6.3 in (159 mm)
1882AN65BS	18 x 8 in (450 x 200 mm)	33.9 in (861 mm)	23.6 in (599 mm)	28.0 in (711 mm)	8.6 in (218 mm)
2480AN65BS	24 x 4 in (600 x 100 mm)	40.7 in (1034 mm)	25.6 in (650 mm)	34.4 in (874 mm)	4.3 in (108 mm)
2481AN65BS	24 x 6 in (600 x 150 mm)	40.7 in (1034 mm)	26.6 in (676 mm)	34.4 in (874 mm)	6.3 in (159 mm)
2482AN65BS	24 x 8 in (600 x 200 mm)	40.7 in (1034 mm)	28.3 in (719 mm)	34.4 in (874 mm)	8.6 in (218 mm)
3080AN65BS	30 x 4 in (750 x 100 mm)	49.4 in (1255 mm)	30.8 in (782 mm)	42.3 in (1074 mm)	4.3 in (108 mm)
3081AN65BS	30 x 6 in (750 x 150 mm)	49.4 in (1255 mm)	31.7 in (805 mm)	42.3 in (1074 mm)	6.3 in (159 mm)
3082AN65BS	30 x 8 in (750 x 200 mm)	49.4 in (1255 mm)	33.5 in (851 mm)	42.3 in (1074 mm)	8.6 in (218 mm)

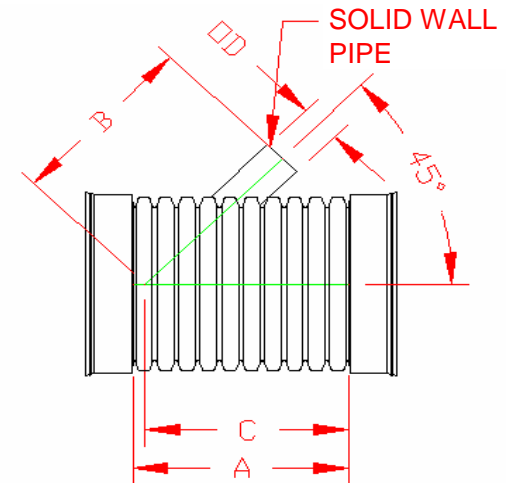

(INCLUDES 2 GASKETS)

NOTE: ALL FITTINGS DIMENSIONS ARE FOR REFERENCE ONLY



DRAWING #:	6105A	
DRAWN BY:	JCB	05.07.07
APPROVED BY:	JCB	06.28.07
REVISIONS:	NJP	06.20.07

TAP REDUCER (ST/WT CONNECTION)

PART #	PIPE SIZE	A	B	OD
0670AN65BS	6 x 4 in (150 x 100 mm)	2.6 in (67 mm)	6.3 in (159 mm)	4.3 in (108 mm)
0870AN65BS	8 x 4 in (200 x 100 mm)	3.2 in (81 mm)	6.5 in (165 mm)	4.3 in (108 mm)
0871AN65BS	8 x 6 in (200 x 150 mm)	3.2 in (81 mm)	6.5 in (165 mm)	6.3 in (159 mm)
1070AN65BS	10 x 4 in (250 x 100 mm)	4.3 in (108 mm)	6.4 in (162 mm)	4.3 in (108 mm)
1071AN65BS	10 x 6 in (250 x 150 mm)	4.3 in (108 mm)	6.4 in (162 mm)	6.3 in (159 mm)
1072AN65BS	10 x 8 in (250 x 200 mm)	4.3 in (108 mm)	6.4 in (163 mm)	8.6 in (219 mm)
1270AN65BS	12 x 4 in (300 x 100 mm)	7.0 in (178 mm)	6.1 in (156 mm)	4.3 in (108 mm)
1271AN65BS	12 x 6 in (300 x 150 mm)	7.0 in (178 mm)	6.1 in (155 mm)	6.3 in (159 mm)
1272AN65BS	12 x 8 in (300 x 200 mm)	7.0 in (178 mm)	6.1 in (155 mm)	8.6 in (218 mm)
1570AN65BS	15 x 4 in (375 x 100 mm)	9.0 in (229 mm)	6.1 in (155 mm)	4.3 in (108 mm)
1571AN65BS	15 x 6 in (375 x 150 mm)	9.0 in (229 mm)	6.1 in (155 mm)	6.3 in (159 mm)
1572AN65BS	15 x 8 in (375 x 200 mm)	9.0 in (229 mm)	6.1 in (155 mm)	8.6 in (218 mm)

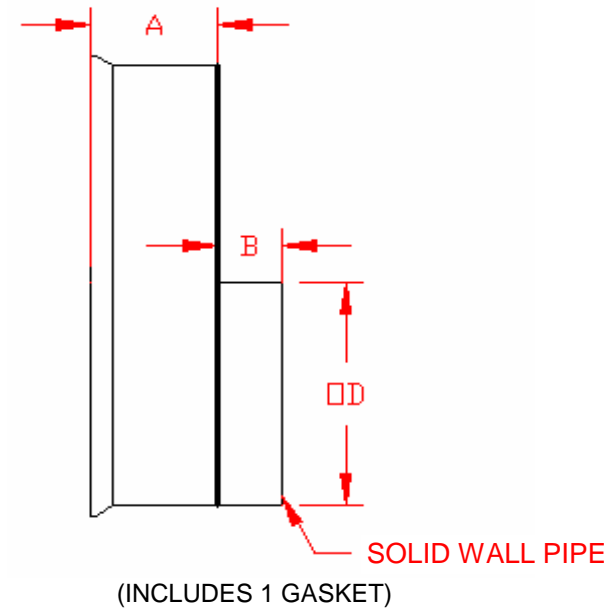

NOTE: ALL FITTINGS DIMENSIONS ARE FOR REFERENCE ONLY



DRAWING #:	6110	
DRAWN BY:	JCB	05.23.07
APPROVED BY:	JCB	06.28.07
REVISIONS:	NJP	06.20.07

TAP REDUCER (ST/WT CONNECTION)

PART #	PIPE SIZE	A	B	OD
1870AN65BS	18 x 4 in (450 x 100 mm)	10.0 in (254 mm)	5.9 in (149 mm)	4.3 in (108 mm)
1871AN65BS	18 x 6 in (450 x 150 mm)	10.0 in (254 mm)	5.9 in (150 mm)	6.3 in (159 mm)
1872AN65BS	18 x 8 in (450 x 200 mm)	10.0 in (254 mm)	5.9 in (150 mm)	8.6 in (218 mm)
2470AN65BS	24 x 4 in (600 x 100 mm)	14.4 in (365 mm)	5.9 in (150 mm)	4.3 in (108 mm)
2471AN65BS	24 x 6 in (600 x 150 mm)	14.4 in (366 mm)	5.9 in (150 mm)	6.3 in (159 mm)
2472AN65BS	24 x 8 in (600 x 200 mm)	14.4 in (366 mm)	5.9 in (150 mm)	8.6 in (218 mm)
3070AN65BS	30 x 4 in (750 x 100 mm)	14.4 in (366 mm)	5.8 in (146 mm)	4.3 in (108 mm)
3071AN65BS	30 x 6 in (750 x 150 mm)	14.4 in (366 mm)	5.8 in (147 mm)	6.3 in (159 mm)
3072AN65BS	30 x 8 in (750 x 200 mm)	14.4 in (366 mm)	5.8 in (147 mm)	8.6 in (218 mm)
3670AN65BS	36 x 4 in (900 x 100 mm)	15.4 in (391 mm)	5.3 in (133 mm)	4.3 in (108 mm)
3671AN65BS	36 x 6 in (900 x 150 mm)	15.4 in (391 mm)	5.3 in (135 mm)	6.3 in (159 mm)
3672AN65BS	36 x 8 in (900 x 200 mm)	15.4 in (391 mm)	5.3 in (135 mm)	8.6 in (218 mm)

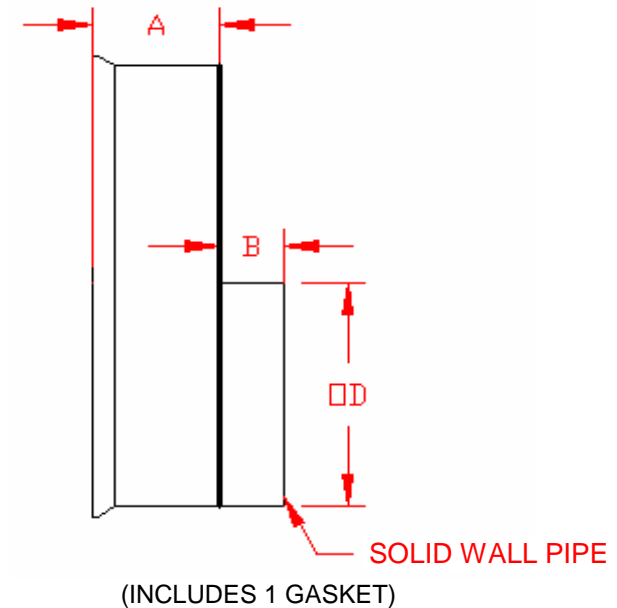

NOTE: ALL FITTINGS DIMENSIONS ARE FOR REFERENCE ONLY



DRAWING #:	6110A	
DRAWN BY:	JCB	05.07.07
APPROVED BY:	JCB	06.28.07
REVISIONS:	NJP	06.20.07

DUAL WALL MITERED JOINT PUSHER

PART #	PIPE SIZE	A	B	C	θ
2408ANMP03	24" (600 mm)	11.0 in (280 mm)	12.5 in (317 mm)	18.8 in (479 mm)	3
3008ANMP03	30 in (750 mm)	14.4 in (366 mm)	16.3 in (413 mm)	36.2 in (918 mm)	3
3608ANMP03	36 in (900 mm)	18.4 in (466 mm)	20.6 in (522 mm)	42.8 in (1086 mm)	3
2408ANMP05	24" (600 mm)	11.0 in (280 mm)	13.5 in (342 mm)	28.9 in (734 mm)	5
3008ANMP05	30 in (750 mm)	14.4 in (366 mm)	17.5 in (444 mm)	36.2 in (920 mm)	5
3608ANMP05	36 in (900mm)	18.4 in (466 mm)	22.0 in (559 mm)	42.9 in (1089 mm)	5
2408ANMP11	24 in (600 mm)	11.0 in (280 mm)	16.6 in (420 mm)	29.3 in (745 mm)	11.25
3008ANMP11	30 in (750 mm)	14.4 in (366 mm)	21.4 in (544 mm)	36.8 in (934 mm)	11.25
3608ANMP11	36 in (900 mm)	18.4 in (466 mm)	26.7 in (677 mm)	43.5 in (1105 mm)	11.25
2408ANMP22	15 x 4 in (600 mm)	11.0 in (280 mm)	22.5 in (573 mm)	31.1 in (790 mm)	22.5
3008ANMP22	30 in (750 mm)	14.4 in (366 mm)	29.0 in (736 mm)	40.0 in (1016 mm)	22.5
3608ANMP22	36 in (900mm)	18.4 in (466 mm)	35.7 in (906 mm)	46.1 in (1172 mm)	22.5

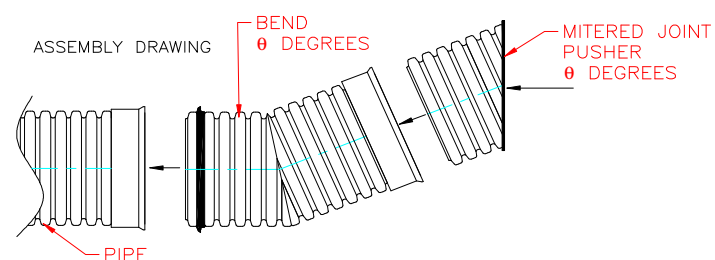
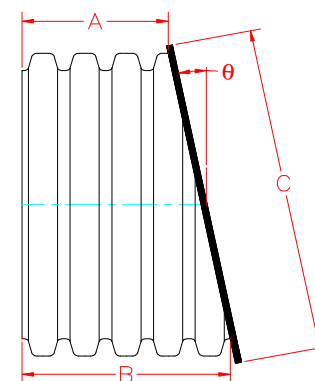

θ REPRESENTS THE DEGREE OF BEND
ONE IS ASSEMBLING.

NOTE: ALL FITTINGS DIMENSIONS ARE FOR REFERENCE ONLY



DRAWING #:	6350	
DRAWN BY:	TJR	12.18.07
APPROVED BY:	TJR	12.18.07
REVISIONS:		